

CONTENTS

	PAGE:
Description	1-2
Schematic diagram of oil-fired system	2
Installation dimensions	3
Installation instructions/plan	4-5
Diagram of connections	6
Electrical connections	7
Technical specifications	8-9
Explanation of terminology	9
Maintenance	10-12
Functional description of operation	13
Description of operation	14
Remedying defects	15
Detachment of combustion chamber	16
Process control diagram	17
Alarm functions	18
Combustion section	19
Voltage control of electrodes	20
Photocell	21
Undervoltage/overvoltage	22
Replacement of fan motor	23
Checking the oil pump magnetic valve	24
Operating thermostat sensor	25
Assembly drawing - list of components	26-27
Electrical diagram	28-29
Digital start clock	30
Stroco 35.00 M EL	31-34
Terms of guarantee	35
Distributors	36

DESCRIPTION

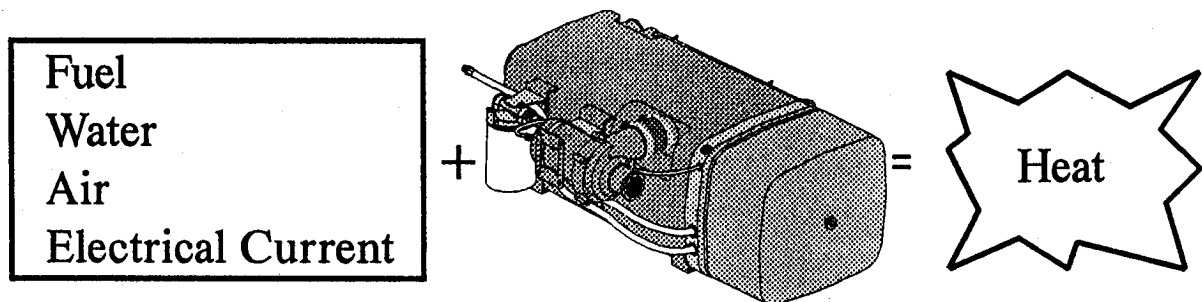

The heat produced by the STROCO oil-fired boiler depends on the presence of the above-mentioned basic elements in the correct amounts and in the correct mixture.

So in case of breakdown or unsatisfactory operation, it is important to check these basic elements first.

The STROCO oil-fired boiler is independent of the motor, and the motor is independent of the boiler. This means that breakdowns in one system do not affect the other. However, the absence of current or gas oil will affect both systems if the motor and oil-fired boiler are connected to the same battery and oil/fuel tank.

The task of the oil-fired boiler is to heat the water in heating systems. This is done by combustion of gas oil at a high temperature in the combustion chamber. This heat is transmitted to the water in the boiler, from where the hot water is pumped to heat emitters.

In other words, this is a continuous process using the water as the connecting medium between the heat producer (boiler) and the heat emitters.

The combustion section is the heart of the boiler. Oil is pumped under pressure to the combustion section, and then atomised in a nozzle. This atomised oil is ignited and a flame established (combustion). Correct combustion of the atomised oil is dependent among other things on a correctly adjusted air supply.

The combustion process and other functions are controlled by the brain of the system - an automatic electronic control/monitoring unit.

This unit ensures that the process takes place according to set routines. If the process deviates from these routines, or if combustion fails or is defective owing to poor supply of the basic elements (oil, water, current and air) the automatic unit will stop the process.

In principle, if all the basic elements are present, combustion will take place. But great efficiency and reliability are expected of the system, so control is also necessary. These instructions should help ensure that the boiler always functions satisfactorily. But if the boiler does not work, or if it does not work perfectly, what should you do?

The section on *Alarm functions* will help you find the source of the problem and analyse the symptoms.

The functional description *Instructions for correcting defects* will explain and illustrate how defects can be remedied.

It is always better to prevent than to cure, so there are certain *Maintenance procedures* which should be carried out and checked to ensure the perfect function of the boiler at all times.

Please see the section on maintenance.

Section 1 of the instructions deals with installation of the boiler, i.e. description of actual installation. The other section deal purely with service and maintenance.

Schematics diagram for oil-fired system

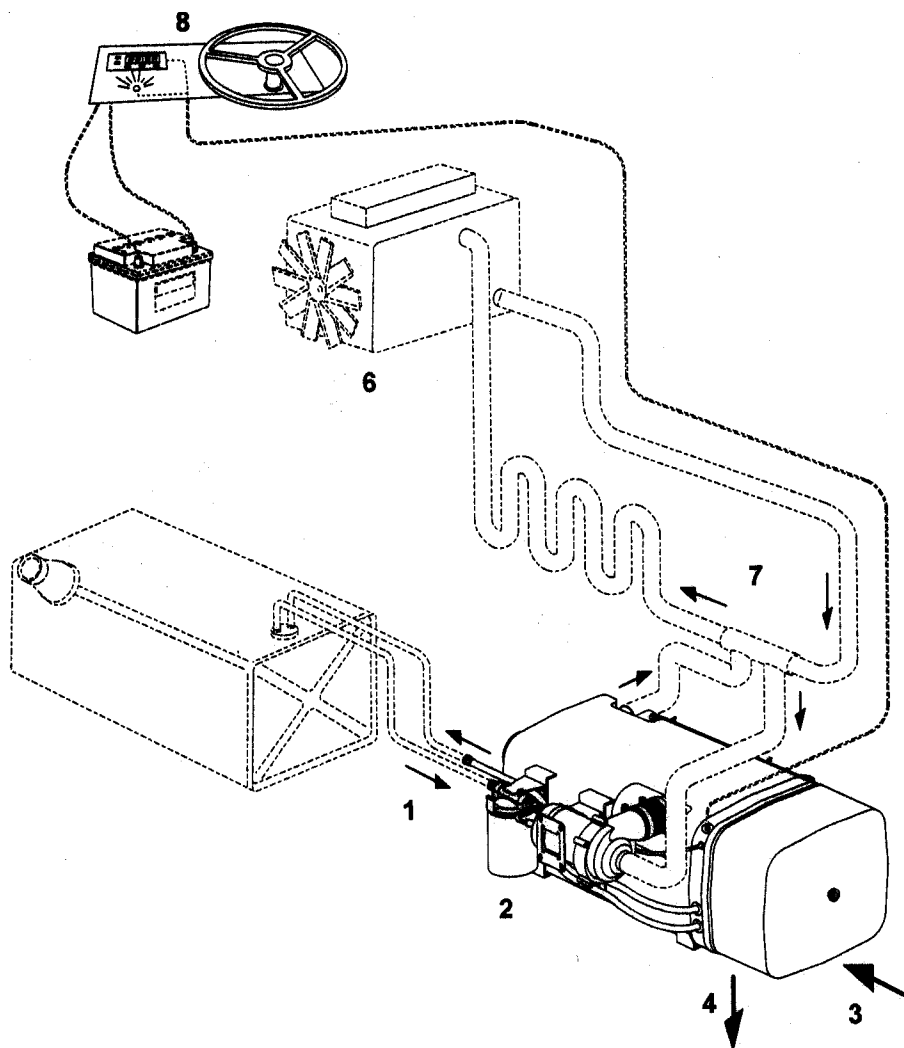

1:Gas oil, 2:Filter, 3:Air, 4:Exhaust, 6:Motor, 7:Heating system, 8:Control panel

INSTALLATION DIMENSIONS

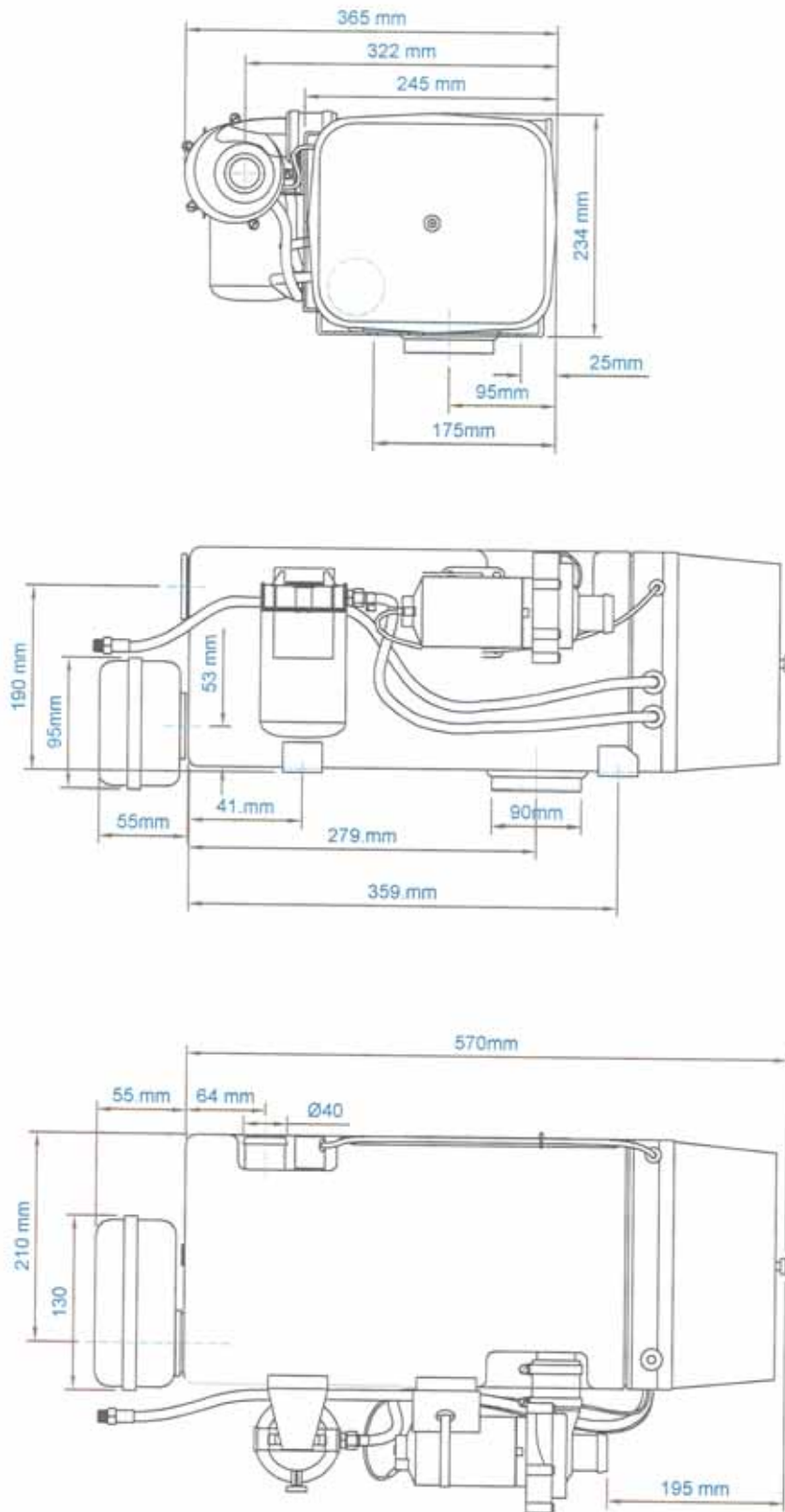

INSTALLATION INSTRUCTIONS/PLAN

These instructions apply to STROCO oil-fired boiler type 35.02 M.

- * **Material and design of the fuel hoses/pipes: TA max. -40°C/+120°C. Use only oil hoses as extensions with copper pipes or similar approved material.**
- * **Non-insulated exhaust pipes/hoses must be at least 7,5 cm away from any flammable material.**
- * **Fuel hoses placed outside the vehicle must be screened to prevent damage. Similarly, electricity cables must not be placed next to fuel hoses.**
- * **Make sure that the boiler is protected from water and splashing from vehicle wheels, and from blows and other damage.**
- * **Install the boiler with a view to ensuring that maintenance work can be carried out easily on the boiler and vehicle components.**
- * **Installation should ensure that heat from the vehicle motor and exhaust system does not damage the boiler. Similarly, the vehicle components should be protected from damage caused by the boiler exhaust.**
- * **Electrical installations leading to the boiler must be installed as specified in SEN 3607111 „Electrical installations for motor vehicles“ or similar standards.**
- * **The water system to which the boiler is connected must be fitted with an over-pressure valve..**
- * **Install the boiler as low as possible in relation to the cooling/heating system.**
- * **If the oil-fired boiler is installed in a box there must be a fresh air intake to the box of at least 100 cm². (the fresh air intake must not be blocked). The box must be made of none-flammable material.**
- * **The air intake to the oil-fired boiler must not come from rooms in which the driver or passengers are sitting. The vehicle exhaust gas must not be connected with the intake air.**
- * **The air intake must be protected from blocking by dirt, snow, etc. It must be placed so that pressure conditions in the system are not affected by the air current from the vehicle.**
- * **The exhaust outlet must be placed so that combustion is not affected significantly by the air current around the vehicle, so that there is no heat damage to adjacent vehicle components, and so that grass etc. cannot be ignited.**
- * **The exhaust pipe must be designed so that local extraction can be connected.**
- * **The vehicle must be protected so that no exhaust gas can reach rooms in which the driver or passengers are sitting.**
- * **The exhaust pipe must not be more than 4000 mm long, and must have a diameter of 90 mm.**
- * **If the boiler is installed in the cab, passenger area or cargo space, this section of the fuel pipe must be made of steel. Connection to the vehicle's fuel system must be made outside the zone concerned.**

INSTALLATION INSTRUCTIONS/PLAN

- * The boiler must not be installed in the driver's or passenger's cab.
- * The exhaust pipe must be made of material which can withstand heat, and which is resistant to corrosion (AISI304 SS 2333 alloy steel that can withstand max. 800°C with at least 0,75 mm thickness).
- * Connections to the exhaust system must be sealed and secured with holders.
- * If the boiler is installed in a cargo compartment the exhaust pipe must be made of a single length of pipe.
- * After installation the type sign must be easily accessible and legible.
- * **THE EXHAUST MUST LEAD OUTSIDE THE VEHICLE IN A HOSE OR PIPE.**

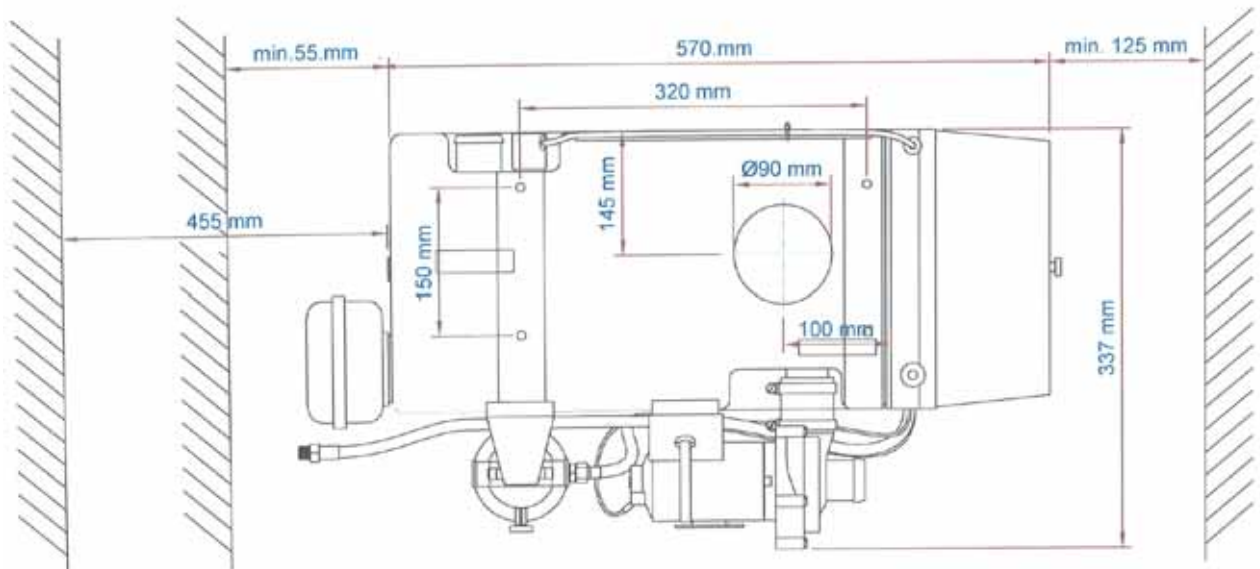

There must be sufficient room by the boiler combustion channel to remove the boiler combustion section and combustion pipe. The minimum distance is shown in the diagram. We recommend installing the boiler on vibration absorbers. In such circumstances flexible hose connections should be installed leading to the boiler.

DIAGRAM OF CONNECTIONS

Connection of water/oil

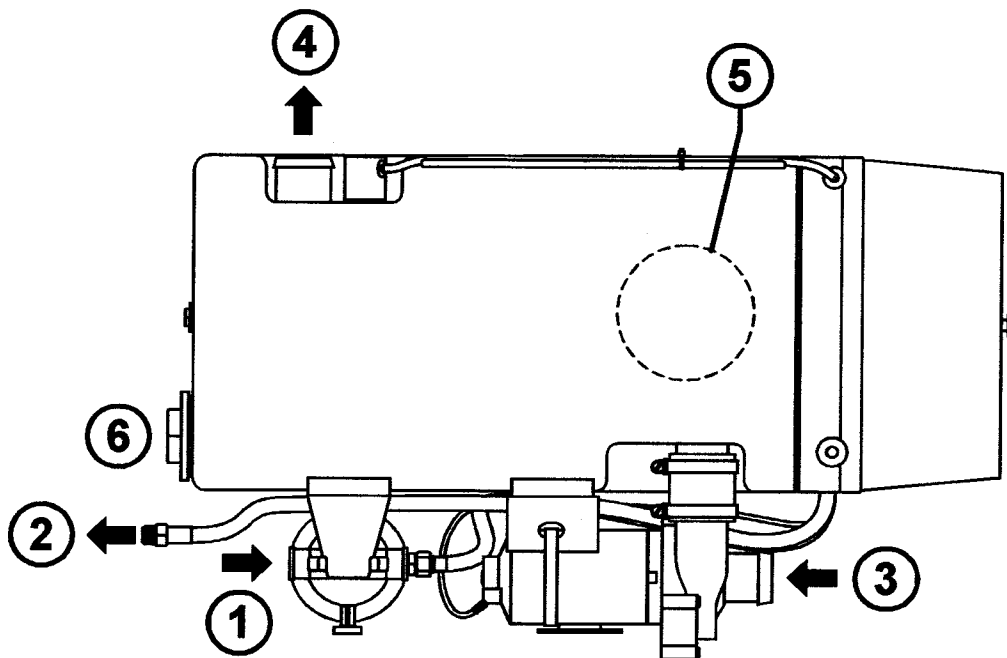

Pos 1: Intake for oil flow (to oil pump from fuel tank):
Connection of oil hose with 14 x 1,25 mm nipple.

Pos 2: Outlet for oil return (to fuel tank):
Oil juse with 14 x 1,25 mm nipplle.

Pos 3: Intake for return water:
Hose connection for 38/40 mm frost-proof hose.

Pos 4: Outlet for flow water:
Hose connection for 38/40 mm frost-proof hose.

Pos 5: Exhaust:
Outside dimensions Ø90 mm.

Pos 6: For connection of extra equipment:
Electrical cartridge for pre-heating water.
Spiral pipe for pre-heating motor fuel.

ELECTRICAL CONNECTIONS

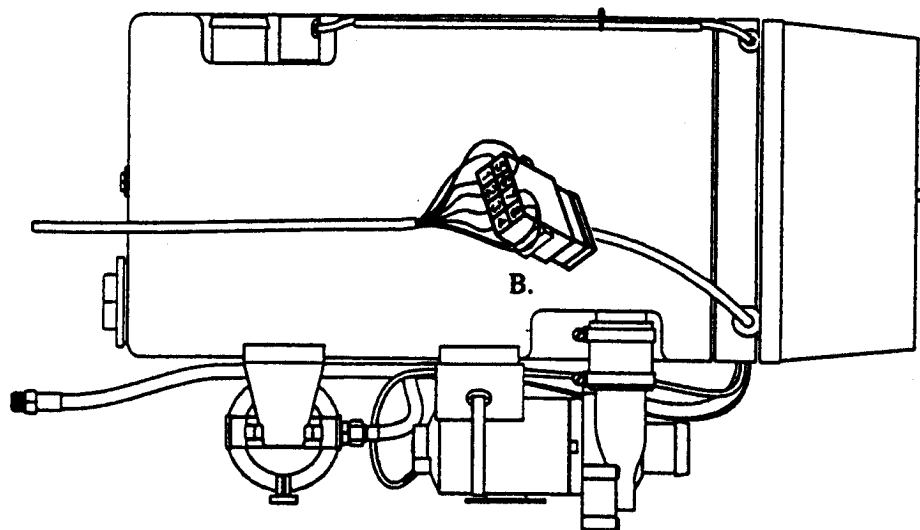

The oil-fired boiler is available in two versions, which can be used for either 24V or 12V. The external connections are combined in an 8-pin plug marked B. The boiler's internal connections are shown in a separate diagram on page 28. Plug B should be connected as follows:

Plug pin B1: Connect to diagnosis light. Connect the other side of the diagnosis light to the + (positive) switch. The diagnosis light must be a light-emitting diode.

Plug pin B2: Connect to - if low temperature is required.

Plug pin B3: Connect via 15A fuse to + (positive).

Plug pin B4: Connect via 8A fuse to + (positive).

NB: the +wires from the two fuses should be joined and connected to the vehicle battery in a 4mm² wire.

Plug pin B5: Connect to relay for room fan.

Plug pin B6: Connect via 8A fuse if separate operation of water pump is required.

Plug pin B7: Connect to main switch or timer. Connect the other side of the switch via 8A fuse to + (positive).

Plug pin B8: Connect to frame (negative).

NB: The boiler can be set to regulate the temperature within two ranges (see pages 8-9: high/low temperature). Select the low range by connecting wire B2 to frame point M. Select the *NORMAL* range by *NOT* connecting B2.

TECHNICAL SPECIFICATIONS

Technical data:

Stroco oil-fired boiler type 35.02 M:	Oil-fired boiler system with built-in automatic control and alarm functions.
Dimensions LxWxH:	570 x 245 x 234 mm
Weight:	30 kg cpl.
Connections:	The oil-fired boiler is connected to the vehicle's electrical installation, fuel tank and water/heating system.
Supply voltage:	24 or 12V DC
Fuel:	Motor diesel oil (gas oil)
Fuel consumption	30kW: Approx. 2,94 kg/h
Fuelfilter:	Filter area: 1937 cm² Degree of filtration: 0,02 mm Connection: 1/4"RG
Heat output:	Output: approx. 30 kW
Power consumption:	approx. 8A at 24V DC (including water pump) approx. 14A at 12V DC (including water pump)
Combustion data:	CO₂: approx. 11%, Soot figure: 0-1 Bacharach
Circulation pump:	approx. 5000 l/h at 0,3 bar
Oil pump:	Working pressure: 7,5 bar (kg/cm²)
Nozzle:	2,94 kg/0,75 Usgal/h 80°H
Photo unit:	Type LDR
Overboiling device:	Type „Therm-o-dise“ Disconnect temperature 110°C
Control thermostat:	NTC 10 K sensor. Boiler temperature: High: stop/disconnect approx. 73/80°C Low: stop/disconnect approx. 55/60°C Cabin ventilator: Start approx. 50°C/Stop approx. 45°C.
MAX. AMBIENT TEMPERATURE:	80°C

IMPORTANT! THE HEATING SYSTEM MUST BE FILLED WITH AN ANTICORROSIVE ADDITIVA (E.G. 40-60% ANTIFREEZE) (SEE MOTOR SPECIFICATIONS)

Pre-ventilation:	On first starting approx. 60 sec. On re-starting approx. 10 sec.
Post-ventilation period:	approx. 120 sec.
Undervoltage:	In 24V units: Disconnect/connect approx. 20,5/22 VDC In 12V units: Disconnect/connect approx . 10,5/11,5 VDC
Overvoltage:	In 24V units: Disconnect/connect approx. 29,5/29 VDC In 12V units: Disconnect/connect approx. 15/14,5 VDC
Safety period:	Max. 15 sec.
Switch load:	Max. 10 Amp
Electrical connection:	15-pin AMP plug (A in electrical diagram)

Explanation of terminology

Low boiler water flow temperature

At low flow temperatures the operating thermostat disconnects at approx. 60°C and re-connects at approx. 55°C. The text refers to this as the low range.

NB: Connect wire B2 if you require a low flow temperature.

High boiler water flow temperature

At high temperatures the operating thermostat disconnects at approx. 80°C and re-connect at approx. 73°C. The text refers to this as the high range, which is the temperature range normally used.

NB: Do not connect wire B2 if you require a high flow temperature.

Overboiling device (max. temperature)

Overboiling of the boiler water can be prevented by using a circuit breaker in the overboiling thermostat which is activated at approx. 110°C. If the system is activated and disconnects the electrical circuit, it can only be re-connected manually by pressing the black button on the thermostat in again. Even though the water has cooled down, automatic starting is not possible.

Safety period in case of flame failure

In case of flame failure the safety relay connects the ignition in an attempt to re-start the system. If no flame is established within the relay safety time of 15 seconds, the relay will disconnect and a post-ventilation period starts. If the safety relay disconnects the defect light will come on.

Pre-ventilation

When the boiler starts there is a pre-ventilation period of 60 seconds, during which time the oil is pre-heated before being released. The pre-ventilation period is reduced to 10 seconds when the boiler is running normally with start/stop controlled by the thermostat.

MAINTENANCE

To ensure the constant reliability of the oil-fired boiler, the following maintenance check should be carried out once the heating season is over, or in good time before it starts:

- * **Replace the oil filter.**
- * **Check the motor coil.**
- * **Check pipe and hose connections for leaks. In particular, make sure that the fuel suction pipe is absolutely leak-proof.**
- * **Inspect the boiler and combustion pipe.**

If the boiler is sooty, the best way of cleaning it, is with high-pressure water (or steam). Protect plugs and motors during cleaning.

If the combustion pipe is corroded, it should be replaced.

- * **Inspect the combustion section.**

The electrode holder with nozzle and turbolator should be clean and intact.

Check the electrode setting (see page 20).

If the boiler is very sooty, the problem may be incorrect combustion, which may make it necessary to replace the nozzle.

The lifetime of the nozzle is limited. Do not try to clean or repair the nozzle, but replace it instead.

Check the air intake and air setting after replacing the nozzle.

Check the photocell and clean it to remove dirt and soot.

- * **When the heating season is over, the boiler should be run for at least 15 minutes each week.**

Checking the pump suction

- * Is there any oil in the tank ?**
- * Does the pump suction system work ?**
- * Does air enter a transparent test hose mounted in the pump suction section?**
- * Is the oil filter or suction pipe blocked ? The pump will whine if the suction section is blocked.**
- * Is the nozzle blocked ?**
- * Is the oil very cold and viscous ?**

Checking the pump pressure

Checking the oil pressure:

Screw a manometer into the pump manometer outlet.

Set the pressure using screw P at 8 bar (kg/cm²).

A variable manometer reading is a sign of air in the suction pipe.

See page 18 if any nozzle defects occur.

Oil filter

The filter is placed on the oil suction pipe between the oil pump and the fuel tank.

After installation the filter arrows should correspond to the direction of flow.

When replacing the filter, check the filter and joints for leaks.

Circulation pump

The circulation pump transports the water around the heating system.

The pump runs constantly while the main switch/start clock is connected and the boiler is operating.

The pump is activated via the water pump relay. The relay receives control current from the automatic system via plug A pin 7.

When the relay is activated, the pump current comes via the relay from main plug B pin 4 (see page 28)..

During operation there must be 24 V(12V) in plug V pin 1.

The motor has permanent magnets.

FUNCTIONAL DESCRIPTION OF OPERATION

The oil-fired boiler can be started by the main switch on the instrument console. The main switch can also be a start clock.

On starting, the control current is connected from the installation (battery 12 or 24V).

The main power supply is connected directly to the boiler's automatic system, which controls the power supply to the boiler.

On starting, the pump relay is activated immediately and starts the circulation pump. The pump runs continuously while the main switch is activated.

The control thermostat gives the signal for the start of combustion when the boiler temperature falls below the set value.

During the *pre-ventilation period* there is a voltage in the ignition electrodes (sparks), the fan motor is running, and there is a power supply to the nozzle pre-heater.

Approx. 60 seconds after the start of operation the oil pump magnetic valve is connected, releasing oil for atomisation in the nozzle. At the same time the *safety timer* is connected.

Once the flame has been formed, the nozzle pre-heater and ignition are disconnected. The start programme has now been completed, and the combustion section will run until the control thermostat disconnects and the *post-ventilation* starts.

When the control thermostat completes the circuit again, the start procedure is repeated with a *pre-ventilation time* of 10 seconds.

Automatic monitoring focuses primarily on the combustion process.

If the oil is *not* ignited on starting, the safety relay will remain connected. After about 10 seconds the safety relay disconnects, and a post-ventilation period starts.

If the flame disappears during operation, the safety relay connects the ignition in an attempt to re-start. If the oil is not ignited the safety relay will disconnect, the release of oil stops, and the alarm is activated. But if the oil is ignited during the re-ignition attempt, combustion will continue until the control thermostat disconnects.

The electrical circuit is controlled automatically, which means that the release of oil stops if component defects occur in the photo or motor circuit.

In case of abnormal operating conditions, such as flame failure during operation or false light in the pre-ventilation time, the boiler is stopped by the automatic safety system and *Alarm functions* are connected.

The automatic system has a built-in fan motor regulator which maintains a constant voltage of app. 21V.

The boiler's *post-ventilation* and *low-voltage logic* are also controlled by the automatic system.

FUNCTIONAL DESCRIPTION

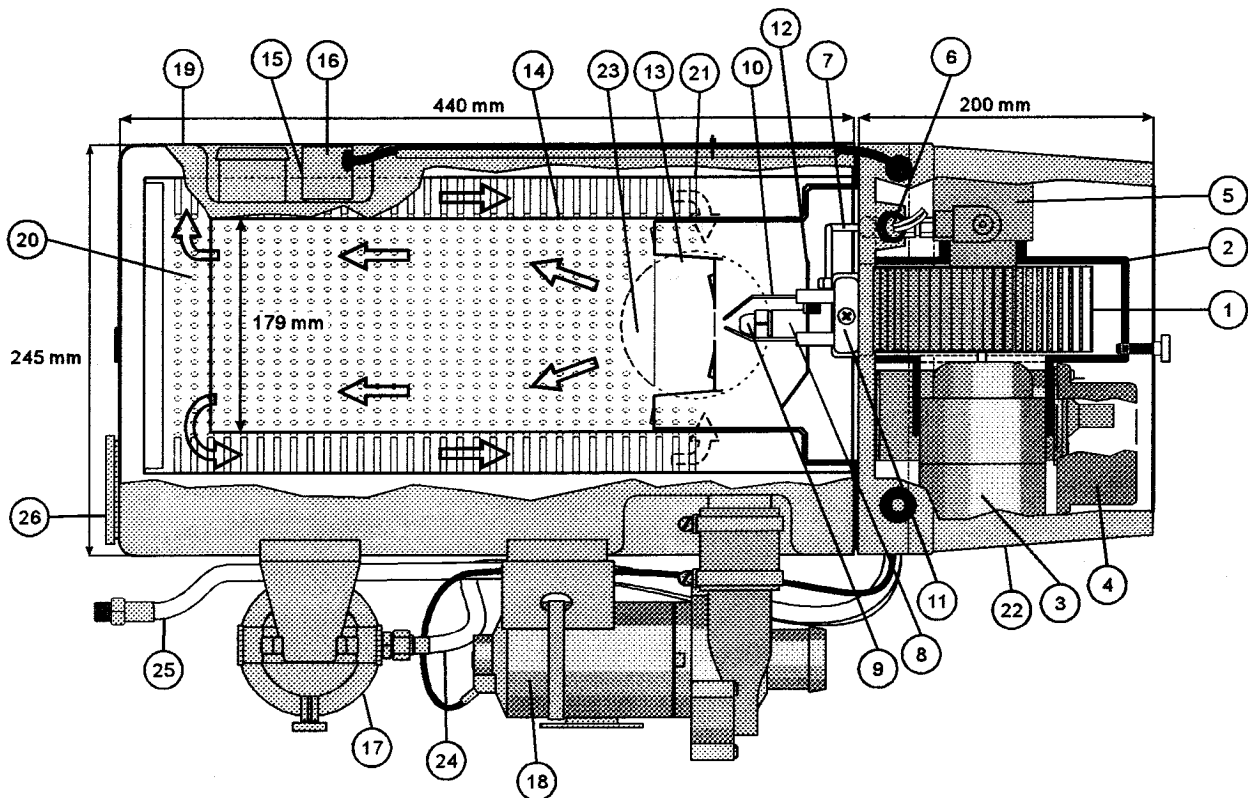

- | | | | |
|----|-------------------------------|----|--------------------|
| 1 | Fan wheel | 14 | Combustion pipe |
| 2 | Fan housing | 15 | Temperature sensor |
| 3 | Motor | 16 | Overboiling device |
| 4 | Automatic system | 17 | Oil filter |
| 5 | Oil pump | 18 | Circulation pump |
| 6 | Photocell | 19 | Outside boiler |
| 7 | Oil pipe | 20 | 22 mm copper pins |
| 8 | Nozzle holder | 21 | Inside boiler |
| 9 | Nozzle | 22 | Plastic cover |
| 10 | Ignition electrode | 23 | Exhaust |
| 11 | Holder for ignition electrode | 24 | Oil hoses |
| 12 | Air plate | 25 | Oil hoses |
| 13 | Combustion section | 26 | Plug |

If the boiler does not work and you start looking for the problem, it is important (if possible) to note the state of the system before and after the defect appears in order to find the source of the defect before starting to use repair tools.

- * Is the main switch or start clock connected ?
- * Is the operating light/diagnosis light on ?
- * Does the defect light/diagnosis light come on when the alarm functions are activated?
- * Were any irregularities observed before defects were noticed ? Smells,sounds or visible changes ?
- * Is there any fuel in the tank ?
- * Is there any water in the system ?
- * Is the power supply to the boiler in order ? 24V plug B pin 3, 4 and 7 (see page 28).
- * Are the air passages to the boiler free ?
- * Are the fuses in the wire network intact ?
- * Is the overboiling device disconnected ?
- * Has the required temperature range been chosen correctly with connection A13 (see page 28) ?

Before going on to remedy defects, you should note the automatic control system of the boiler in various sequences. Certain functions such as pre-ventilation and ignition only run for limited periods.

If the boiler is disconnected from the automatic system owing to defects, post-ventilation will continue for approx. 120 seconds and the diagnosis light of the automatic system will indicate a defect (see page 17).

Repairs etc. must only be performed by qualified personnel.

DETACHMENT OF COMBUSTION CHAMBER

Detach the plug for the overboiling device and the operating thermostat sensor.

Access to the combustion pipe can be gained by detaching the oil-fired boiler using the two 8 mm nuts (pos. 1). Withdraw the boiler, and the combustion pipe (pos. 2) will then be free.

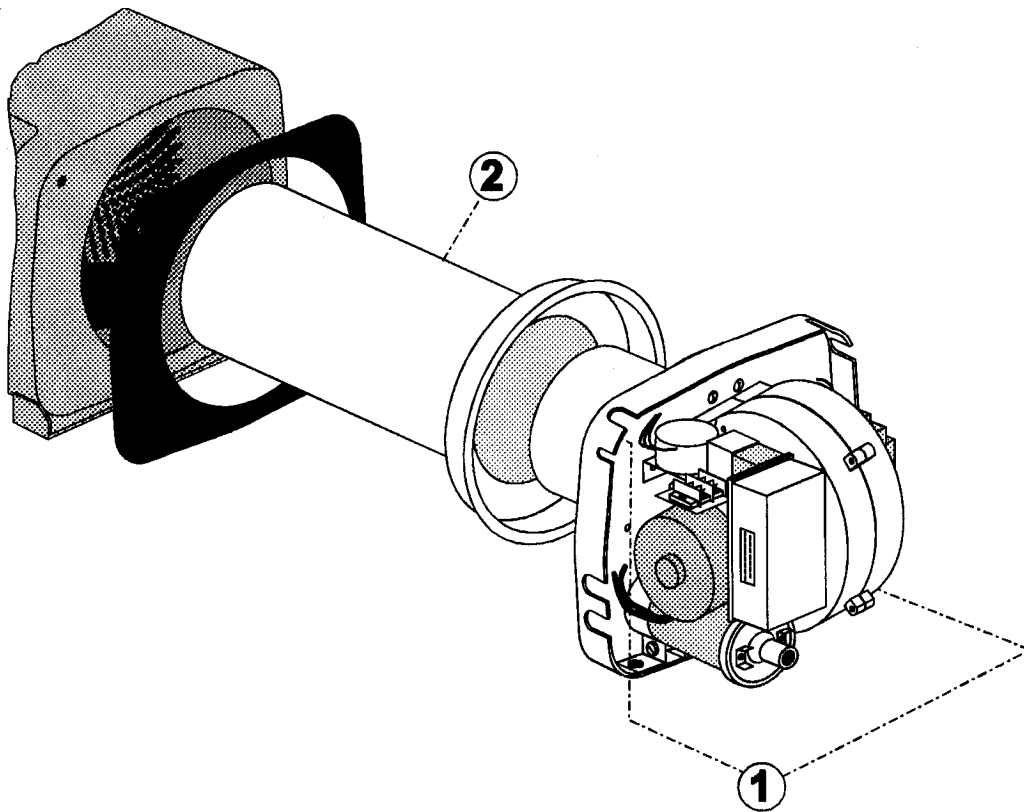

PROCESS CONTROL DIAGRAM

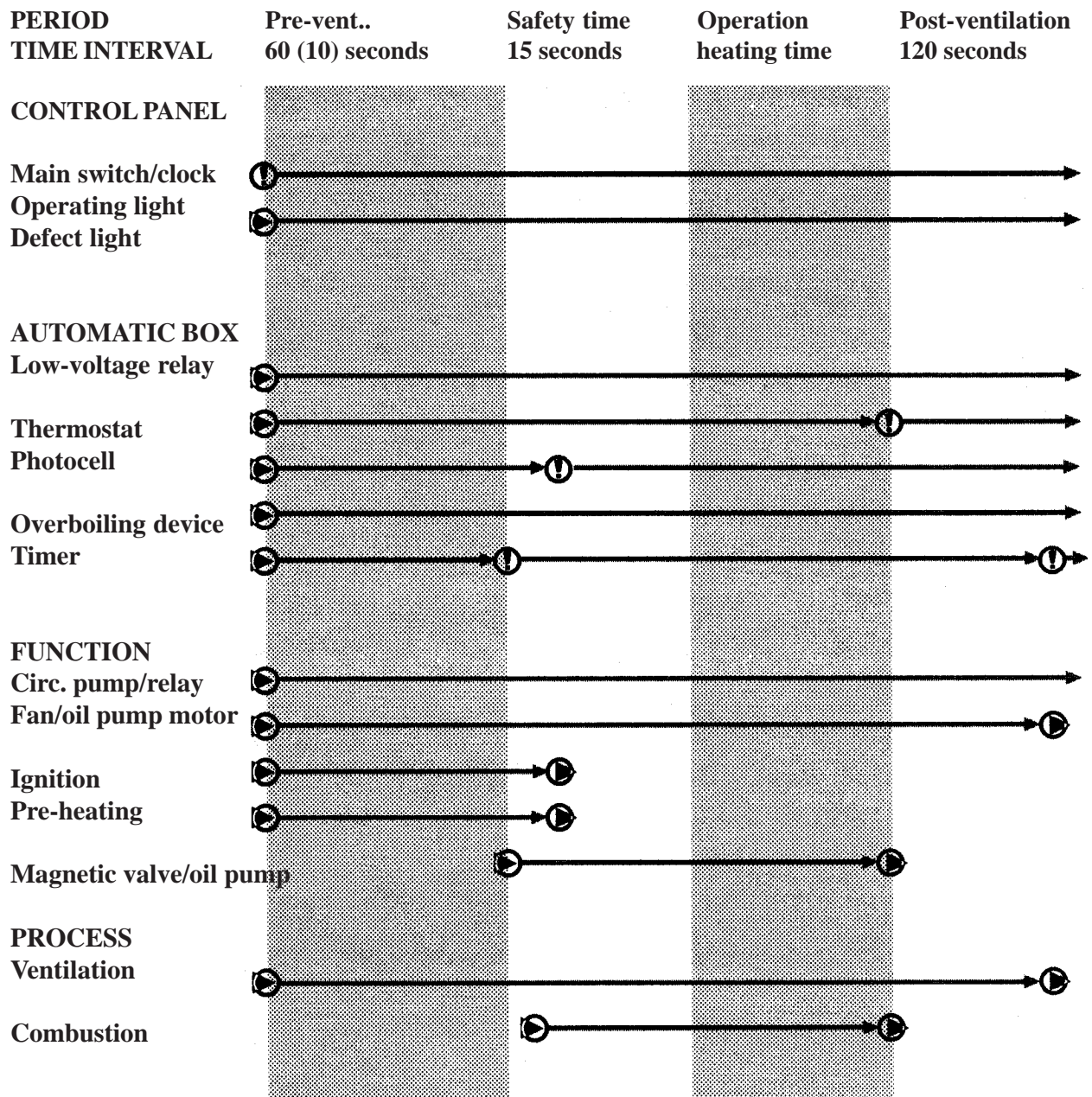

*Note: When starting first time the the pre-ventilation time is 60 seconds
When starting during the operating period the pre-ventilation time is 10 seconds*

Symbols:

- ⊙ :Signal for either connection or disconnection
- : Connection
- ⊙ :Disconnection

Note: THE OIL-FIRED BOILER MUST NOT BE USED IN GARAGES, PETROL STATIONS, OR WHEREVER THE USE OF OPEN FLAMES IS PROHIBITED!

ALARM FUNCTIONS

Type of defect	With LED indicator (seconds)	display indicator	Remedy
0 Normal operation		0	
1 Safety time exceeded		1	page 19
2 Ignition electrode defective		2	page 20
3 Photodetector defective		3	page 21
4 Undervoltage		4	page 22
5 Overvoltage		5	page 22
6 Fan defective		6	page 23
7 Magnetic valve defective		7	page 24
8 Sensor defective		8	page 25
9 Too many start attempts		9	(reset at operation and light)
10(A) Overboiling alarm		R	page 25

IMPORTANT !

Boilers with LED indicators;

Black field means red light.

White field means no light.

Dotted field means flashing.

The combustion section is the heart of the combustion process. Air and atomised oil are mixed in the combustion section and ignited by the ignition spark from the ignition coil.

The flame is registered by the photocell.

The correct setting of the combustion section is important to ensure an effective combustion process:

- * The position of the ignition electrodes in relation to the nozzle.
- * The distance between the two electrodes.
- * The position of the electrodes in relation to the turbolator.

Why is there no flame ?

Possible reasons:

- There is no oil in the tank.
- The suction pipe is leaking.
- There are air pockets in the suction pipe.
- There is no suction from the oil pump.
- The oil pump is not rotating because the connection is defective.
- The oil pump pressure is too low.
- The pump magnetic valve is not releasing oil to the nozzle.
- Dirt is being drawn up from the oil tank and blocking the nozzle.
- The oil is very cold and therefore highly viscous.
- The suction and return oil pipes have been exchanged.
- There is no spark, owing to the defective ignition coil/oscillator or ignition cable.
- There is no spark, owing to short-circuited electrodes, oil coke or a sooty covering on the insulator.

Manual re-connection

If the automatic system is disconnected via the safety relay, it can be re-connected by disconnecting the main switch on the instrument console for approx. 5 seconds, after which it should be re-connected. The boiler will then start in normal fashion.

VOLTAGE CONTROL OF ELECTRODES

This should be carried out in connection with checking the ignition coil and ignition oscillator. Detach the plug for the overboiling device, the operating thermostat sensor and the magnetic coil. When checking ignition the plug for the overboiling device should be short-circuited to make the ignition work.

Access to the combustion section can be gained by detaching the boiler's end flange. Screw off the two 8 mm nuts, and remove the boiler.

The discharge by the electrodes can now be checked as described.

The ignition system receives current for the ignition oscillator and ignition coil from the automatic system via plug A pin 2 (see page 28)..

The ignition coil and oscillator are connected to each other, and cannot work separately.

The ignition oscillator chops the operating voltage minus into impulses which are transformed by the ignition coil into high voltage, which is then discharged in the form of a spark between the ignition electrodes.

If discharge does not occur, the reason may be:

1. A defective ignition cable.
2. The electrode setting.
3. Dirt on the electrodes.
4. Defective ceramic coating on the electrode unit.
5. The ignition coil, oscillator, automatic system.

Electrodes should be set according to the dimensioned sketch below.

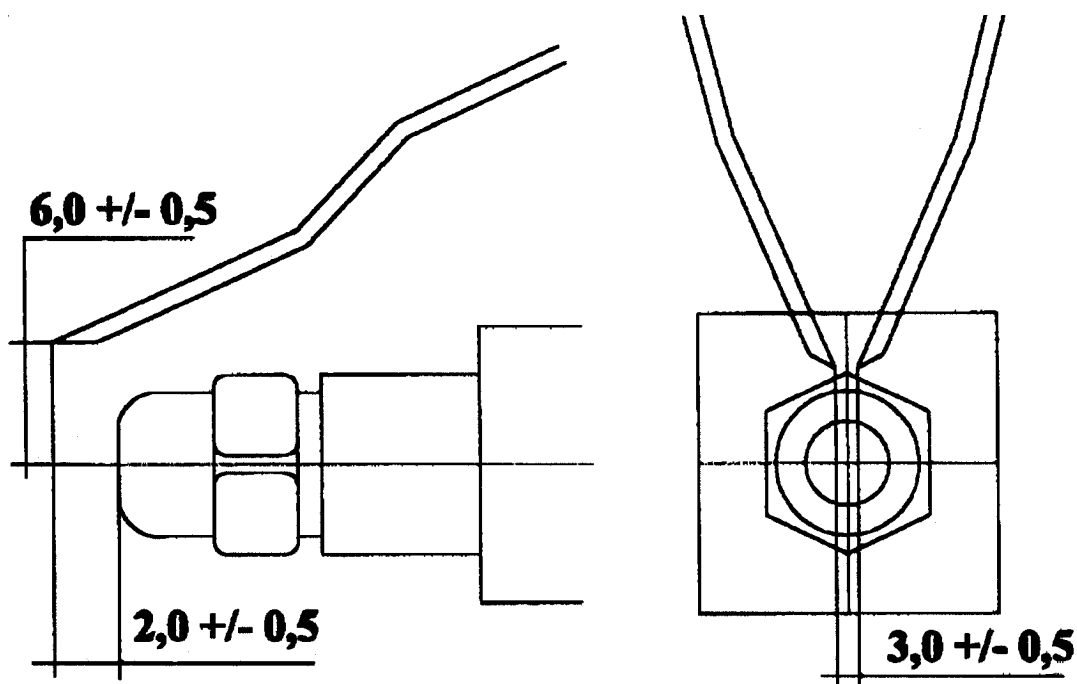

During the pre-ventilation period the photocell must not be exposed to light, because this will prevent the boiler from starting.

When the pre-ventilation time stops and the oil is released for combustion the photocell must be exposed to light, because otherwise the safety relay will disconnect and the process will be stopped.

The photocell is connected to the automatic system via plug D (see page 28)..

Adjustment and remedying of defects

If the photocell's light-sensitive LDR sensor is short-circuited or defective, the oil-fired boiler will not start because the automatic system will be disconnected.

If the photocell receives insufficient light when a flame is alight, the automatic system will disconnect.. This may be due to dirt on the sensor itself, or to the fact that the photocell is not positioned correctly in the combustion section. Defects in the photocell can be remedied by replacing the photocell and seeing if a new one works better.

The photocell can be separated in plug D (see page 28).

UNDERVOLTAGE/OVERVOLTAGE

Undervoltage

If the voltage is below 22/11.5 V (in step 0) and below 20.5/10.5V during pre-ventilation, operation and post-ventilation, the undervoltage alarm will be activated. The alarm can only be reset with the switch off and the voltage above 22/11.5V.

Overvoltage

If the voltage is above 29.5/15V the alarm is activated, and if it is below 29/14.5V the alarm is reset.

REPLACEMENT OF FAN MOTOR

The motor can be replaced by detaching the fan housing from flange no. 1 and then dismantling the fan housing. Detach the fan housing wheel, and then the two 4 mm screws that hold the motor in position.

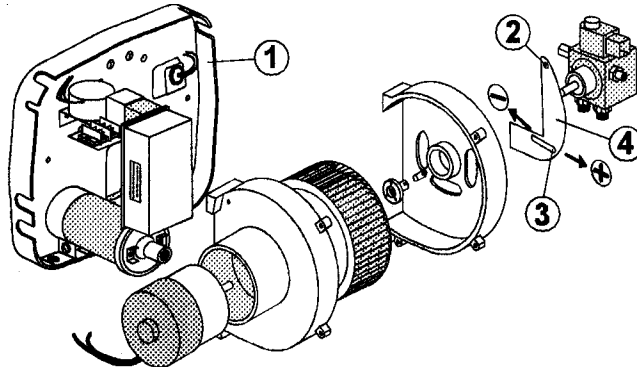

Setting the amount of air

The amount of air for combustion can be adjusted by loosening screws no. 2 and 3 and turning air valve no. 4 + and -.

The air setting has an influence on whether the oil is combusted incompletely and emit soot (black smoke), or whether there is a surplus of air (blue smoke).

The correct setting can be measured in the smoke:

The CO₂ (carbon dioxide) content of the smoke should be 10-11% and the soot figure should be 0-1 Bacharach.

Oil pre-heater

The pre-heater is mounted in the nozzle holder, which it heats.

The pre-heater starts to work when the boiler is started, but is disconnected during operation.

The purpose of the pre-heater is to ensure that the flame is created when starting cold.

The pre-heater is controlled by the automatic system, and is powered via plug F, approx. 3 Amp (see page 28).

Oil pump

- The oil pump is mounted on the fan housing using two 6 mm screws.

- The pump is mounted in a two-pipe system, with ventilation taking place automatically through the return pipe.

- The pump magnetic valve is activated from the automatic system via plug L (see page 28).

- The pump working pressure must be 7,5 bar (kg/cm²). The pressure can be set using screw P (see page 11).

- The pump is operational while the fan motor is running, but the oil is not released for atomisation in the nozzle until the magnetic valve is activated.

- It is important that the pump suction pipe has absolutely no leaks, and that an oil filter is mounted in the suction pipe (Stroco type 2000).

CHECKING THE OIL PUMP MAGNETIC VALVE

Before checking the magnetic valve, measure the voltage supply to the coil. The voltage should be approx. 24V (12V) in plug L pin 2 (see page 28).

NB: There is no voltage in the plug until after the pre-ventilation period and the voltage will disconnect again after approx. 10 seconds unless the photocell registers combustion. (See diagram for normal operation on page 17).

If the voltage in connector L, pin 2 (see page 28) is in order, check the magnetic coil's drawing power. The coil core should become magnetic when there is a voltage present (a screwdriver can be used).

If the photocell is exposed to light during pre-ventilation, this is registered as a defect in the magnetic valve. This defect can only be reset when the switch is set at off.

OPERATING THERMOSTAT SENSOR

The operating thermostat sensor is connected to the automatic system in plug C (see page 28). The sensor is screwed into a holder on the side of the boiler, and registers the temperature in the boiler.

The thermostat can be set for two operation ranges:

- 1: **Disconnect/Break: approx. 55/60°C**
NB: Choose this temperature range by connecting wire B2 to the the frame.
- 2: **Disconnect/Break: approx. 73/80°C (the normal range).**
NB: Choose this temperature range by not connecting wire B2 to the frame.

Adjustment and remedying defects

Defects in the thermostat become apparent when the heating process continues beyond the pre-set temperature range and is finally disconnected by the overboiling device.

The voltage measurements across an intact thermostat sensor will show:

Falling voltage as the temperature rises. When the voltage across the sensor has fallen to approx. 1.2V, the thermostat will disconnect (for the normal temperature range).

On the other hand, the voltage will rise as the temperature falls. At approx. 3.6V the thermostat will connect (for the normal temperature range).

If the voltage measured is constant and does not depend on the temperature, the sensor must be defective, making it impossible to adjust the thermostat.

Replace the sensor by detaching plug C (see page 28), after which the sensor can be screwed out of its base.

Overboiling device (max. temperature)

This device ensures that the temperature of the boiler water cannot exceed a maximum of 110°C.

The overboiling device is screwed into a holder on the boiler section next to the thermostat sensor.

If the device disconnects when the maximum temperature is exceeded, the defect light will come on.

The device cannot be re-connected by attempting to re-start via the main switch, but must be connected manually by pressing the overboiling device's black button in. Connection cannot occur until the boiler temperature has fallen.

Adjustment and remedying defects

Before and after re-connection of the overboiling device, it is important to discover the reason for the disconnection.

- 1 Is there water in the system ?
- 2 Has the system been ventilated correctly ?
- 3 Is the thermostat in order ?

ASSEMBLY DRAWING - LIST OF COMPONENTS

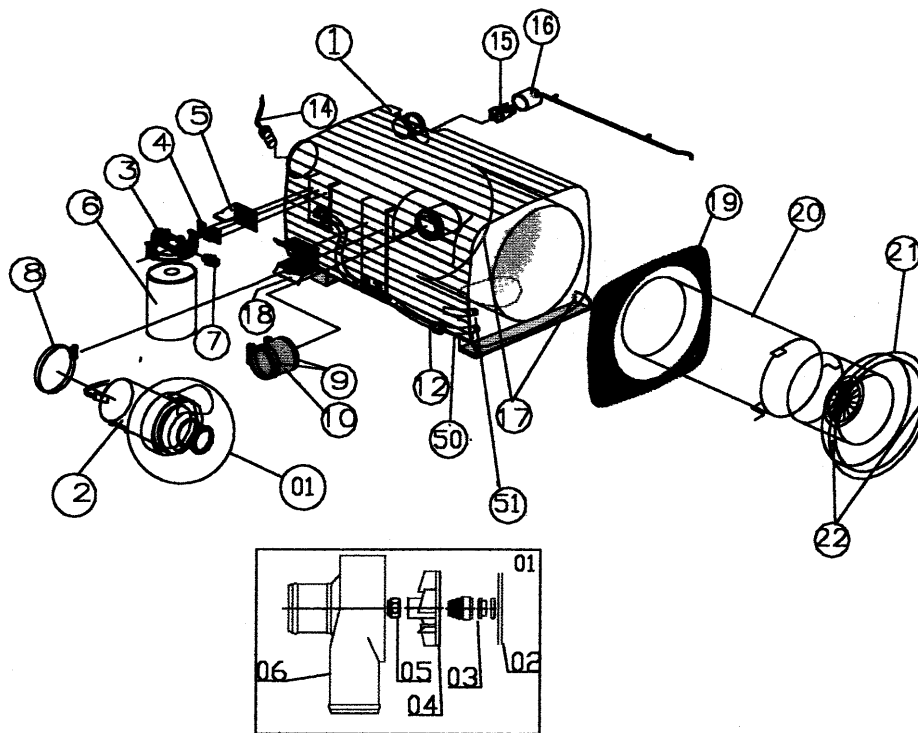

Pos.	Designation	Order number
1	Boiler	35.541
2	Circulation pump 24/12V	35.440/35.442
3+4	Oil filter cpl.	11.038
5	Fitting for oil filter	35.015
6	Oil filter cartridge	11.037
7	Nipple 1/4 x 1/4 thread	30.390
8	Clip 68-85	35.020
9	Clip 32-44	35.021
10	Rubber hose	35.022
12	Oil hose	31.400
14	Temperature sensor	35.010
15	Overboiling device	35.030
16	Cable for overboiling device	35.031
17	Support bolt 8 mm	35.023
18	Fitting for water pump	35.027
19	Sealing ring	35.028
20	Combustion pipe	35.042
21	Combustion section	35.041
22	Screw 4 mm	35.024
23	Nut 8 mm	35.026
50	Oil line flow	35.016
51	Oil line return	35.018
01	Water pump gasket set comp.	35.485
02	O-ring 65 x 3	35.429
03	Water pump gasket	30.480
04	Water pump rotor	35.410
05	Nut 8 mm self-locking	35.014
06	Water pump housing	35.422

ASSEMBLY DRAWING - LIST OF COMPONENTS

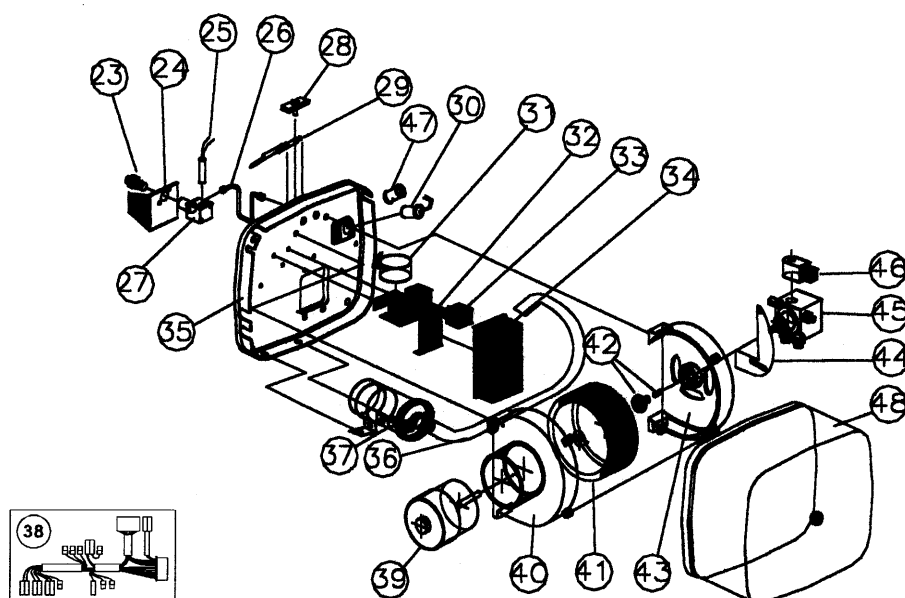

Pos.	Designation	Order number
23	Nozzle	35.070/35.071
24	Air plate	35.080
25	Pre-heater element	31.142
26	Oil pressure pipe cpl.	35.250
27	Nozzle holder	30.130
28	Electrode fitting	35.029
29	Electrode	35.100
30	LDR photocell	31.160
31	Ignition oscillator	35.510
32	Fitting for relay holder and frame connection clamp	35.033
33	Relay for circulation pump	31.190
34	Automatic system 24/12V	35.520/35.522
35	Flange	35.036
36	Ignition cable	35.170
37	Ignition coil 12/6V (24/12V)	30.490/30.492
38	Wiring set cpl.	35.570
39	Fan motor 24/12V	35.340/35.342
40	Fan housing, motor section	35.037
41	Fan wheel	35.270
42	Connection cpl.	35.360
43	Fan housing (input)	35.032
44	Air valve	35.300
45	Oil pump	31.370
46	Magnetic coil 24/12V	31.375/31.377
47	Nut for photocell	35.140
48	Plastic cover	35.034
	Angle	30.390 NOT SHOWN ON DRAWING
	Oil line flow	35.016 NOT SHOWN ON DRAWING
	Oil line return	35.018 NOT SHOWN ON DRAWING
	Nylon nut	20.230 NOT SHOWN ON DRAWING
	Stopper for overboiling device	35012 NOT SHOWN ON DRAWING

ELECTRICAL DIAGRAM

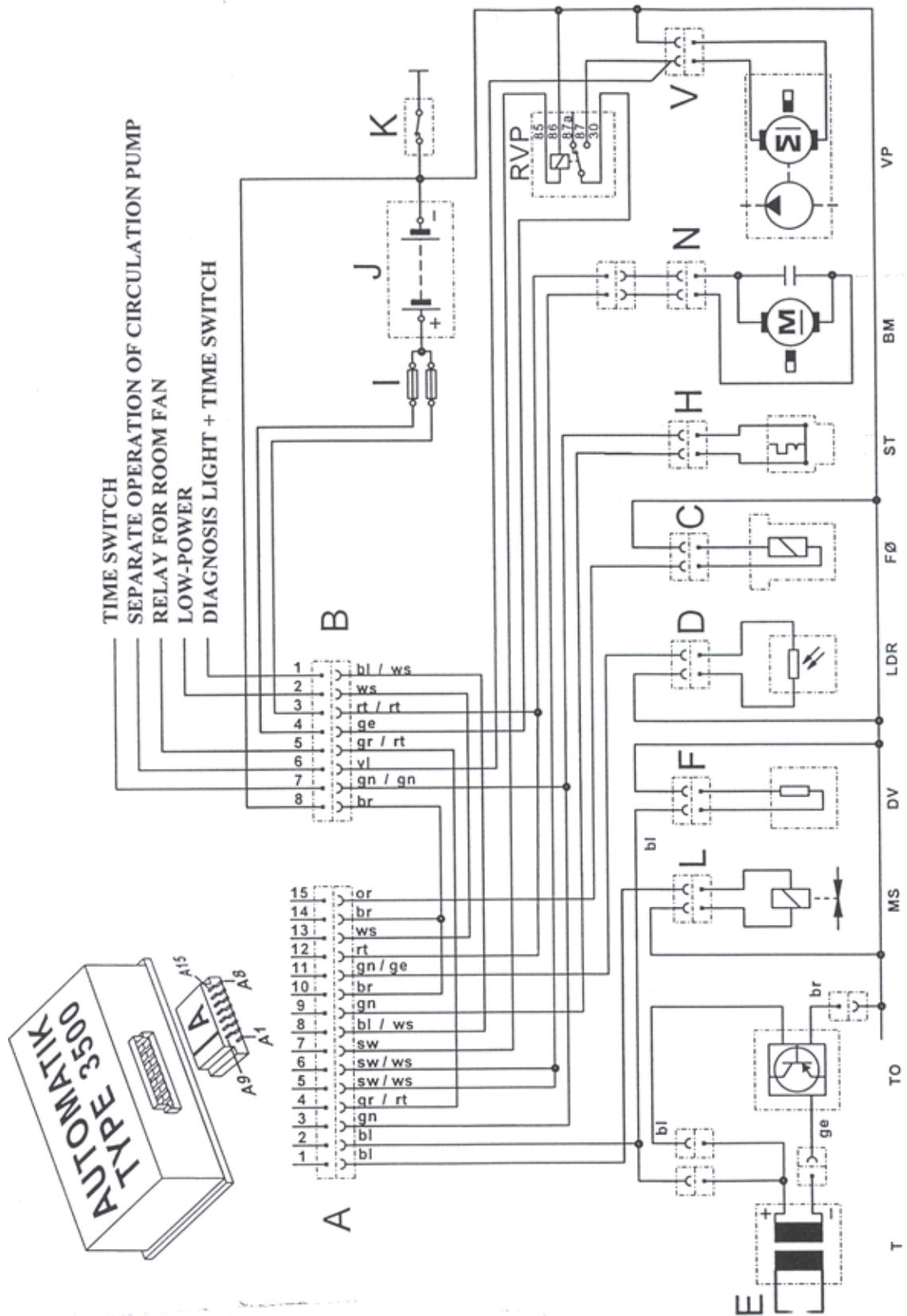

Key to abbreviations		Colour codes
A	Plug for automatic system	bl blue
	Automatic: Electronic controlunit	br brown
B	Main plug	ge yellow
BM	Fan motor	gn green
C	Plug for operating thermostat	gr grey
D	Plug for photocell	or orange
E	Ignition electrodes	rt red
F	Plug for nozzle preheater	sw black
H	Plug for priming fuse	ws white
L	Plug for magnetic coil	vl purple
LDR	Photocell	
ST	Priming fuse	
N	Plug for fan motor	
FØ	Sensor for operating thermostat	
RVP	Relay for circulation pump	
T	Ignition coil	
TO	Ignition oscillator	
V	Plug for circulation pump	
VP	Circulation pump	
DV	Nozzle preheater	
MS	Magnetic coil	
I	Fuse 8A	
J	Accumulator	
K	Circuit breaker	

DIGITAL START CLOCK

Installation

Install the start clock in the driver's cab in a protected position so that it will not cause personal injury in case of collision.

The clock can be installed in the instrument panel or the central console, if there is room. For such installation a rectangular hole is needed with the dimensions 85 x 40 mm.

Technical data

Voltage range: At 12V: 9.....15 volt
At 24V: 18.....30 volt

Temperature range for operation: -40°C.....+75°C

Power consumption with display off: (closed current: $\leq 1,0\text{mA}$)

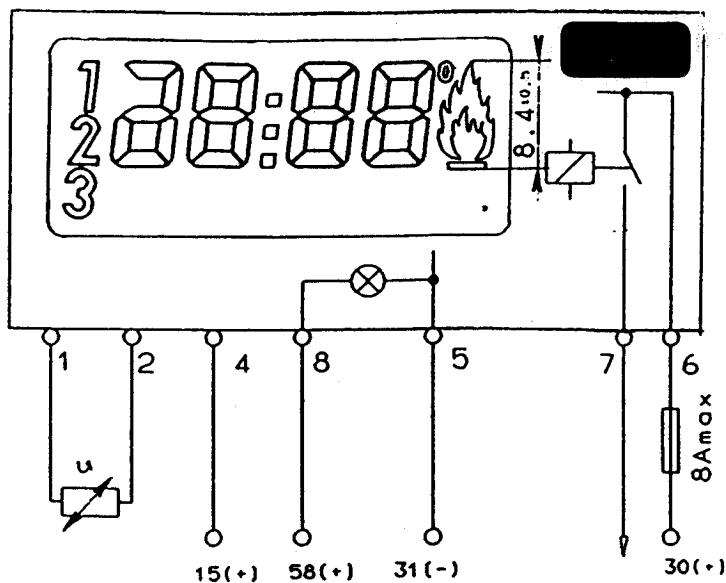

Electrical connections



Pin 1-2	(Remote thermostat)
Pin 4	Ignition +
Pin 5	Minus -
Pin 6-8	Plus +
Pin 7	Control current +

LABELLING STROCO 35.00 M EL

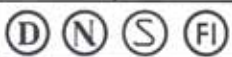
The heater labelling is as shown below and consists of a model plate and a warning label.

stroco ingenjör & handelsfirma DK 8450 HAMMEL TLF. +45-86 96 10 66			
V~	400 3N	W	9000
Hz	50	TYPE	9 EL
IP			KLI
Vare	Bus motorvarmer		
			

MÅ KUN
TILSLUTTES
STIKKONTAKT
MED JORD 

 *KYTKETTÄVÄKSI
AINOASTAAN
MAADOITETTUUN
PISTORASIAAN*

 *FÅR ENDAST
ANSLUTAS TILL
JORDAT
UTTAG* 

DESCRIPTION/TECHNICAL SPECIFIC. STROCO 35.00 M EL

Description

The Stroco 35.00 M electrical heater is designed primarily for heating vehicles in unheated garages or in places where central heating cannot be used. The heater is fitted to the vehicle's existing heating system and can therefore heat both the vehicle engine and the driver's cabine. The heater consists of a boiler with built-in heating elements, an operating thermostat and a safety thermostat. The model codes 3, 6 and 9 kW denote the heating element output in kW. The heater should be connected to the mains supply via a EURO socket mounted on the vehicle. To provide water circulation, a circulation pump should be installed with electrical connection from the heater. The direction of the water circulation should follow the normal installation procedure. The pumping direction of the circulation pump is denoted with an arrow on the circulation pump.

Stroco 35.00 M EL should be fitted so that it is possible to remove the cover on the electrical unit.

Technical specifications

Model	Stroco 35.00 M EL type 3, 6 and 9 kW
Heat output:	3, 6 or 9 kW
Electrical connection:	3 x 400 V via 5 pole EURO-plug (incl. neutral and earth).
Operating thermostat:	variable from 5-85°C
Safety thermostat:	110°C, reset by push button
Circulation pump:	Grundfos UPS 25-40 180 or 130: Electrical connection 1 x 230 V Output 30-80 W in three levels Capacity 38 l/min at 2 m/vs Dimensions 180 x 130 x 140 mm The pump must always be fitted with the axle horizontal

ELECTRICAL INSTALLATION AND SETTINGS

The following is a description of the electrical installation and relates to the diagram on the next page.

1. Internal wiring

Wiring between the three parts of the installation, namely heater, circulation pump and EURO plug must be executed with at the minimum 1 mm² ordinary plastic coated wire HO7 N-F. The wiring must be inserted in the heater tag block by pressing down with a small screwdriver at L.

Wiring must be protected by flexible 3/8" armoured hose with metal inserts (e.g. Stroco no. 11.865). The armoured must have PG11 threaded joints at the ends with clamping ring fittings to relieve the weight on the hose (e.g. Stroco no. 11.867). Where the hose may be subject to vibrations it must be further fixed with cable clips.

Check that the thermostat is turned up.

NB! Turn up the thermostat and press the overheat button before starting.

2. EURO-sockets

Connections to the mains grid must be via a permanently mounted 5-pole EURO-socket (e.g. Stroco no. 11.861).

The socket should be mounted at a point on the vehicle which is protected from water and dirt. The socket opening must face downwards, so that condensate can run out.

The label supplied „Only to be used with an earthed socket “ must be placed in a visible position on or at the side of the socket.

3. Earth connections

Earth connections may only be carried out as shown in the diagram on the next page. Earth connections between individual parts must always be enclosed in armoured hose.

The earth connections from H to K leading to the vehicle chassis must be executed in 4 mm² wire. At the vehicle chassis, paint and rust must be thoroughly cleaned away. As a minimum, a Ø3,5 mm self-cutting or threaded screw with a toothed washer must be used.

Earth connections G to the lid of the boiler's electrical compartment may not be removed.

4. Thermostats

The operating thermostat D can be set at any point between 5°C to 85°C. The thermostat has an in-built hysteresis of 12 K, i.e. there is an interval of 12°C between switching in and out.

Operating temperature is set with a screwdriver at D.

Safety thermostat E switches off as soon as the temperature exceeds 110°C. The thermostat can be reset by pressing button E.

NB: Setting and resetting of thermostats may only be done after removing the plug from the mains.

5. Circulation pump

Circulation pump C has three speeds 1, 2 and 3 which are set at button F. If the return pipe to the heater is hot, a lower speed can be selected.

DIAGRAM

11904
11811
11861
11912

- A Heater
- B Circulation pump
- C EURO socket
- D Operating thermostat
- E Safety thermostat
- F Circulation pump adjustment
- G Earth connection to lid
- H Outer earth connection
- K Earth connection to chassis
- L Tag block
- M Heating elements
- N Capillary tube sensors

11913

- bl blue
- ge yellow
- gn green
- sw black

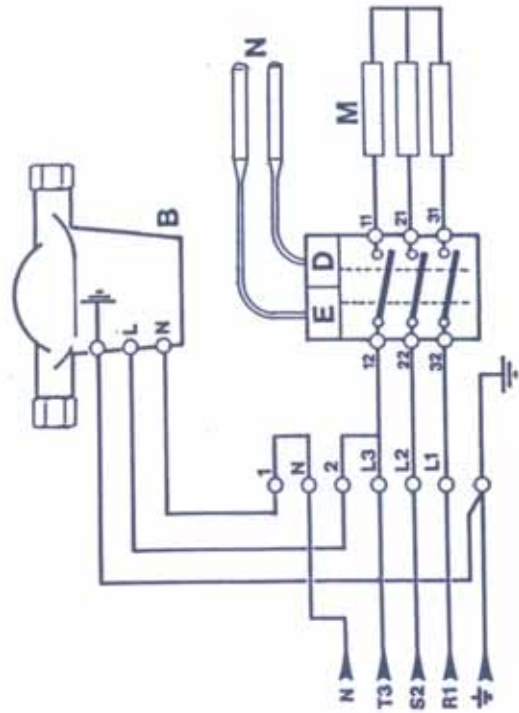
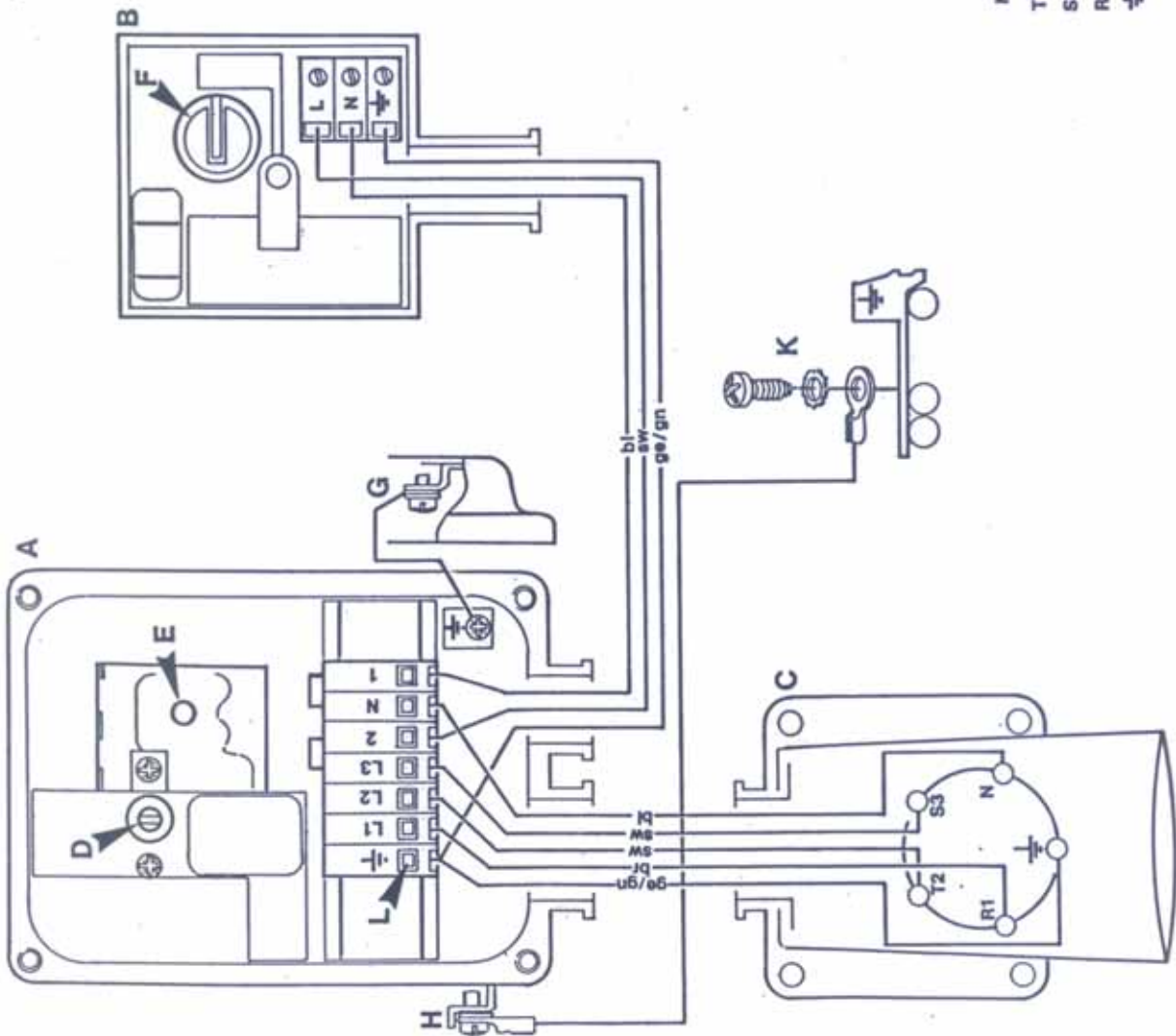

Terms of guarantee for STROCO oil-fired boilers

There is a 12 months guarantee on STROCO oil-fired boilers and their parts, calculated from the date of installation (maximum 2 years from our date of delivery).

The guarantee covers manufacturing and/or material defects

If there are any changes in the system, or if the system is not installed in accordance with our directions, the guarantee no longer applies.

During the guarantee period *STROCO* undertakes to repair systems or components which our inspection shows to be defective. Repairs can also be carried out at our service workshops.

Nozzles are not covered by the guarantee.

Wages paid in connection with dismantling of defective parts will not be reimbursed

If defects are discovered in the system during the guarantee period, defective parts must be sent *postage paid* to *STROCO* stating the defect concerned and the *delivery date/boiler number*.

STROCO's decision as to whether any material or manufacturing defects are present shall be final and binding on the purchaser in all cases.

Consequential loss

STROCO assumes no liability for personal injury, damage to property or operating losses resulting in the boiler supplied, no matter what the cause (including manufacturing defects).



STROCO



DANMARK, Denmark:

STROCO ApS
Ingeniør- & Handelsfirma
Norgesvej 2
DK-8450 Hammel

Tlf. 86 96 10 66
Fax 86 96 96 47

NORGE, Norway:

VEST-BUSSCAR SERVICE AS
Leiraveien 12
N-2000 Lillestrøm

Tlf. 63 89 19 50
Fax 63 89 19 60

FINLAND:

EL-CAR OY
Jukka Eerola
Sienitie 9 C
SF-00760 Helsinki

Tlf. 09 389 4995
Fax 09 389 4995

SVERIGE, Sweden:

TK BUSSKLIMAT AB
Järnringen 2
S-433 30 Partille

Tlf 31 44 52 00
Fax 31 44 52 65

SCHWEIZ, Switzerland:

AUTOKÜHLER AG
Wiesackerstrasse 133
CH-8105 Regensdorf

Tlf 1 840 65 00
Fax 1 840 60 80

ENGLAND:

CLAYTON TRANSPORTATION
Hunter Terrace
Fletchword Gate, Burnshall Road
GB-Coventry CV5 6SP

Tlf 0024 7669 1916
Fax 0024 7669 1969

PORTUGAL:

PROJECTIVA
Zona Industrial
P-2350 Torres Novas

Tlf (049) 819 240
Fax (049) 819 249

ØSTRIG, Austria:

JOSEF ZIMMER
Hetzendorfer Strasse 55
A-1121 Wien

Tlf 804 15 23 0
Fax 804 15 23 48